



POWERPLUS[®]
POWERPLUS GROUP INC., USA



MINI EXCAVATOR

PP40S-XI

CORPORATE OVERVIEW

POWERPLUS GROUP INC., USA, a leading global manufacturer of a comprehensive range of construction equipment, is part of Worldwide Techno-Equipment Group (1973) Pte Ltd. Established since 1973, POWERPLUS GROUP has evolved into a world-renowned organization that offers machinery unparalleled in price, quality and performance.

POWERPLUS machinery is manufactured with enhanced capacities to exceed even the most stringent international standards of quality and safety. With the aim of producing machinery that is able to withstand even the most extreme climatic conditions and rugged terrains, POWERPLUS Research & Development team which has its Headquarters in the United States, has been the backbone behind all its innovative engineering solutions.

Optimizing the best of technology from the United States, Europe and Japan, POWERPLUS machinery is configured to its ideal technical capabilities. A multinational team of engineers analyzes the data collected from our network of distributors worldwide and are on the constant lookout for ways to maximize the life-span of POWERPLUS machinery.

Today the Company's clientele spans over 100 countries across 6 continents.

At the forefront of setting quality standards, every POWERPLUS machine undergoes a technical review after 2 years and is tested rigorously before a new model is churned out of its production facility.

With an emphasis on delivering value and excellent after-sales service to our customers, the POWERPLUS experience outshines and outclasses its competitors in all aspects.

INTRODUCING THE WORLD'S BEST EXCAVATORS

POWERPLUS Excavators can be counted on to deliver unparalleled performance and unmatched versatility. Easy to maintain, efficient engines and powerful hydraulics make POWERPLUS Excavators the most reliable in the industry.

Combining engineering excellence with a dedication to quality, POWERPLUS Excavators are made durable and hardy to meet the challenges of various applications. With a full line of models, there is a POWERPLUS Excavator to fuel your every mining or construction need. POWERPLUS Excavators are known for their exceptional durability, industry leading technology and innovation.

When it comes to cost efficiency, POWERPLUS Excavators make for one of the lowest cost-per-ton options for moving materials in their class, giving you significant savings and better ROI.

KEY COMPONENTS

- KUBOTA engine
- Steel bushing for boom linkage
- Italian technology heat treatment bucket teeth

PP40S-XI

MAIN SPECIFICATIONS

Operating Weight	kg	3800
Rated Bucket Capacity	m ³	0.12
Maximum Digging Force	kN	30.4
Swing Speed	rpm	12
Maximum Gradeability	°	30

ENGINE

Model	Kubota D1703	
Rated Power	hp	25
Rated Speed	rpm	2200
Emission	Euro 5	

UNDERCARRIAGE

Travel Speed (High/Low)	km/h	4.4 / 2.4
Ground Pressure	kPa	32
Track Rollers	1	
Carrier Rollers	4	

HYDRAULIC SYSTEM

Main Pump	POWERPLUS	
Maximum Flow	L/min	88
Working Pressure	MPa	22.5
Hydraulic Oil Tank Capacity	L	44

CABIN

An ergonomically designed sound proof cabin, enabling wide operational view, comes standard with designer upholstery, adjustable POWERPLUS mechanical suspension driver's seat, streamline dashboard, aircon and radio/mp3 player for extensive operations with well deserved comfort.

DIMENSIONS

A	Overall Length	mm	4915
B	Overall Width	mm	1720
C	Overall Height	mm	2525
D	Counterweight Ground Clearance	mm	595
E	Minimum Ground Clearance	mm	295
F	Track Length	mm	2154
G	Track Gauge	mm	1420
H	Track Width	mm	1720
I	Track Shoe Width	mm	300
J	Turntable Width	mm	1550
K	Front Turning Radius	mm	2530
	Boom Length	mm	2535
	Arm Length	mm	1400

WORKING RANGE

L	Maximum Digging Height	mm	4800
M	Maximum Dumping Height	mm	3406
N	Maximum Digging Depth	mm	3208
O	Maximum Vertical Digging Depth	mm	2957
P	Maximum Digging Reach	mm	5480
Q	Maximum Digging Reach At Ground Level	mm	5359

SERVICE REFILL CAPACITY

Fuel	L	40
Hydraulic Oil	L	44
Engine Oil	L	7
Final Drive	L	2X0.7

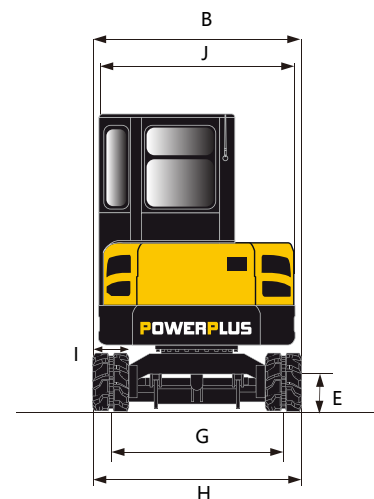
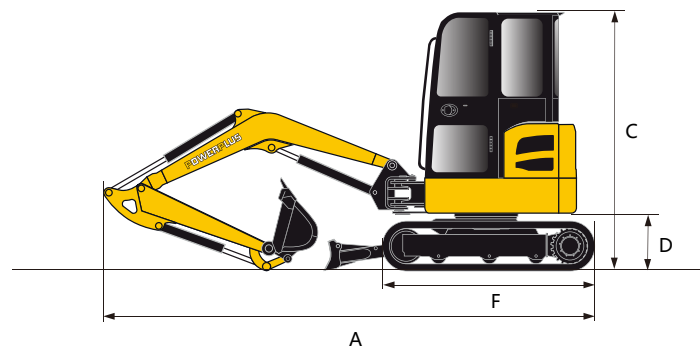
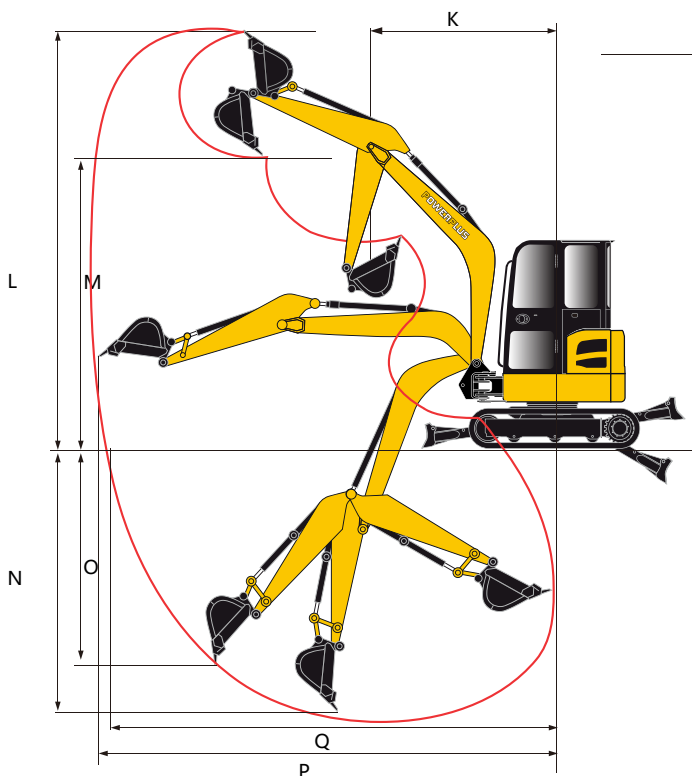

www.powerplus.us

International Division

POWERPLUS GROUP PTE. LTD.

Powerplus Building
39 Ubi Crescent, Singapore 408587
Tel: (65) 63399333
Fax: (65) 63399933
Email: enquiry@powerplus.us

Research & Development Facility

POWERPLUS GROUP INC., U.S.A.

2130 N. Arrowhead Avenue,
San Bernardino, CA 92405, USA
Tel: (1) 909 300 3333
Fax: (1) 909 323 3333
Email: hq@powerplus.us

Distributed By:

 **POWERPLUS** is the registered TM of  **POWERPLUS GROUP INC., USA**
In the United States of America & Worldwide

All rights of manufacturer and of this book reserved. Unauthorized duplication is a violation of application law.

Part of:  **WORLDWIDE TECHNO-EQUIPMENT GROUP (1973) PTE. LTD.**